

Radiation Hardened 5-channel Bus Transceiver with cold sparing

1 GENERAL DESCRIPTION

The AP54RHC506 is a radiation-hardened by design 5-bit bus transceiver with 3-state outputs that is ideally suited for space, medical imaging and other applications demanding radiation tolerance and high reliability. It is fabricated in a 180 nm CMOS process utilizing proprietary radiation-hardening techniques, delivering high resiliency to single-event effects (SEE) and to a total ionizing dose (TID) up to 30 krad (Si).

This device is a member of the Apogee Semiconductor AP54RHC logic family operating across a voltage supply range of 1.65 V to 5.5 V.

An output enable control pin allows all buffers to be placed in a high impedance (high-Z) state, simplifying usage in applications with shared busses or mixed power domains. A direction control pin is used to determine whether data flow is A→B or B→A.

Zero-power penalty™ cold-sparing is supported, along with Class 2 ESD protection on all inputs and outputs. A proprietary output stage and robust power-on reset (POR) circuit allow the AP54RHC506 to be cold-spared in any redundant configuration with no static power loss on any pad of the device. The redundant output stage also features a high drive capability with low static power loss.

The AP54RHC506 also features a triple-redundant design throughout its entire circuitry, which allows it to be immune to single-event transients (SET) without requiring additional redundant devices.

Ordering information may be found in Table 9 on Page 12.

1.1 FEATURES

- 1.65 VDC to 5.5 VDC operation
- Inputs tolerant up to 5.5 VDC at any V_{CC}
- Provides logic-level down translation to V_{CC}

- Extended operating temperature range (-55 °C to +125 °C)
- Proprietary **cold-sparing capability** with zero static power penalty
- **Built-in triple redundancy** for enhanced reliability
- Internal power-on reset (POR) circuitry ensures reliable power up and power down responses during hot plug and cold sparing operations
- Tri-state output drivers
- Class 2 ESD protection (4000 V HBM, 500 V CDM)
- TID resilience of **30 krad (Si)**
- SEL resilient up to LET of **80 MeV-cm²/mg**

1.2 LOGIC DIAGRAM

The AP54RHC506 logic function is shown below:

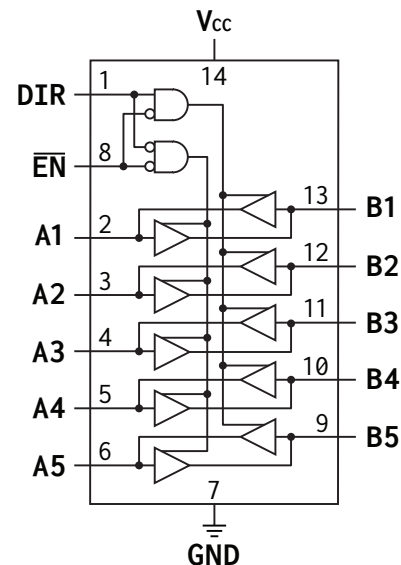

Figure 1: AP54RHC506 logic diagram

CONTENTS

1	General Description	1	5.6	Characteristics Measurement Information	8
1.1	Features	1	6	Detailed Description	9
1.2	Logic Diagram	1	7	Applications Information	10
2	Acronyms and Abbreviations	2	7.1	Use in Cold-Sparing Configuration	10
3	Logic Data	3	7.2	Power Supply Recommendations	10
4	Pin Configuration	3	7.3	Application Tips	10
5	Electrical Characteristics	4	8	Packaging Information	11
5.1	Absolute Maximum Ratings	4	9	Ordering Information	12
5.2	Recommended Operating Conditions	5	10	Revision History	12
5.3	Static Characteristics	6	11	Legal	13
5.4	Dynamic Characteristics	7			
5.5	Radiation Resilience	7			

LIST OF TABLES

1	Truth Table	3	6	DC Electrical Characteristics	6
2	Device Pinout	3	7	AC Electrical Characteristics	7
3	Absolute Maximum Ratings	4	8	Radiation Resilience Characteristics	7
4	Recommended Operating Conditions	5	9	Ordering Information	12
5	Thermal Information	5			

LIST OF FIGURES

1	AP54RHC506 logic diagram	1	6	Input Pin Structure	9
2	Device Pinout	3	7	Output Pin Structure	9
3	Load Circuit	8	8	Cold Spare Example	10
4	Propagation Delay	8	9	Package Mechanical Drawing	11
5	Enable and Disable Timing	8	10	Part Number Decoder	12

2 ACRONYMS AND ABBREVIATIONS

ESD	Electrostatic Discharge
POR	Power On Reset
RHA	Radiation Hardness Assurance
SEE	Single Event Effects
SEL	Single Event Latchup
SET	Single Event Transient
TID	Total Ionizing Dose
TMR	Triple Modular Redundancy
CDM	Charged-device Model
HBM	Human-body Model

3 LOGIC DATA

The AP54RHC506 truth table is found in Table 1. **H** indicates HIGH logic level, **L** indicates LOW logic level, **X** indicates DON'T CARE and **Z** indicates HIGH-Z (TRI-STATE).

Table 1: AP54RHC506 device truth table

EN	DIR	Function
H	X	All buffers tri-state (HIGH-Z)
L	L	A bus to B bus
L	H	B bus to A bus

4 PIN CONFIGURATION

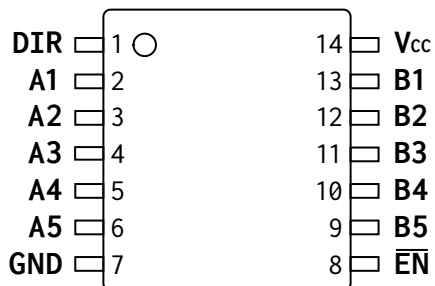

Figure 2: AP54RHC506 device pinout overview

Table 2: AP54RHC506 device pinout description

PIN NAME(S)	PIN NUMBER(S)	DESCRIPTION
A1, A2, A3, A4, A5	2, 3, 4, 5, 6	A Side Inputs (DIR = L) or 3-State Outputs (DIR = H)
B1, B2, B3, B4, B5	13, 12, 11, 10, 9	B Side Inputs (DIR = H) or 3-State Outputs (DIR = L)
DIR	1	Direction Control Input
$\overline{\text{EN}}$	8	Output Enable (active-low)
V _{CC}	14	Positive Voltage Supply
GND	7	Ground

5 ELECTRICAL CHARACTERISTICS

The sign convention for current follows JEDEC standards with negative values representing current sourced from the device and positive values representing current sunk into the device.

5.1 ABSOLUTE MAXIMUM RATINGS

Excursions beyond the values listed in Table 3 may cause permanent damage to the device. Proper function of the device cannot be guaranteed if these values are exceeded, and long-term device reliability may be affected. Functionality of the device at these values, or beyond those listed in [Recommended Operating Conditions](#) (Table 4) is not guaranteed.

All parameters are specified across the entire operating temperature range unless otherwise specified.

Table 3: Absolute Maximum Ratings

SYMBOL	PARAMETER	VALUE	UNITS	
V_{CC}	Supply Voltage	-0.5 to +5.5	V	
V_I	Input voltage range	-0.5 to +5.5	V	
V_O	Output voltage range	-0.5 to $V_{CC} + 0.5$ ⁽¹⁾	V	
$I_{IK} (V_I < 0)$	Input clamp current	100	mA	
I_O	Continuous output current (per pin)	100	mA	
I_{CC}	Maximum supply current	100	mA	
V_{ESD}	ESD Voltage	HBM	4000	V
		CDM	500	V
T_J	Operating junction temperature range	-55 to +150	°C	
T_{STG}	Storage temperature range	-65 to +150	°C	

⁽¹⁾ V_O must remain below absolute maximum rating of V_{CC}

5.2 RECOMMENDED OPERATING CONDITIONS

All recommended parameters below are specified across the entire operating temperature range unless otherwise specified.

Table 4: Recommended Operating Conditions

SYMBOL	PARAMETER	MIN	MAX	UNITS	
V_{CC}	Supply voltage	1.65	5.5	V	
V_I	Input voltage range	0	5.5	V	
V_O	Output voltage range	0	V_{CC}	V	
V_{IH}	HIGH-level input voltage	$V_{CC} = 1.65$ to 1.95 V	1.4	-	V
		$V_{CC} = 2.3$ to 2.7 V	1.9	-	
		$V_{CC} = 3.0$ to 3.6 V	2.5	-	
		$V_{CC} = 4.5$ to 5.5 V	3.8	-	
V_{IL}	LOW-level input voltage	$V_{CC} = 1.65$ to 1.95 V	-	0.4	V
		$V_{CC} = 2.3$ to 2.7 V	-	0.6	
		$V_{CC} = 3.0$ to 3.6 V	-	0.9	
		$V_{CC} = 4.5$ to 5.5 V	-	1.35	
I_{OH}	HIGH-level output current	$V_{CC} = 1.65$ to 1.95 V	-	-4	mA
		$V_{CC} = 2.3$ to 2.7 V	-	-8	
		$V_{CC} = 3.0$ to 3.6 V	-	-16	
		$V_{CC} = 4.5$ to 5.5 V	-	-24	
I_{OL}	LOW-level output current	$V_{CC} = 1.65$ to 1.95 V	-	4	mA
		$V_{CC} = 2.3$ to 2.7 V	-	8	
		$V_{CC} = 3.0$ to 3.6 V	-	16	
		$V_{CC} = 4.5$ to 5.5 V	-	24	
t_r, t_f	Input rise or fall time (10% - 90%)	$V_{CC} = 1.65$ to 1.95 V	-	1000	ns
		$V_{CC} = 2.3$ to 2.7 V	-	600	
		$V_{CC} = 3.0$ to 3.6 V	-	500	
		$V_{CC} = 4.5$ to 5.5 V	-	400	

Table 5: Thermal Information

SYMBOL	PARAMETER	MIN	TYP	MAX	UNITS
T_J	Operating junction temperature	-55	-	+125	°C
$R_{\theta JA}$	Junction to ambient thermal resistance	-	100	-	°C/W

5.3 STATIC CHARACTERISTICS

All parameters are specified across the entire operating temperature range unless otherwise specified.

Table 6: DC Electrical Characteristics

SYMBOL	PARAMETER	CONDITIONS	V _{CC}	MIN	TYP	MAX	UNITS
V _{OL}	LOW-level output voltage	I _O = 100 μA	1.65 to 5.5 V	-	0.02	0.05	V
		I _O = 1 mA	1.65 to 5.5 V	-	0.05	0.1	V
		I _O = 4 mA	1.65 V	-	0.4	0.8	V
			2.3 V	-	0.3	0.6	V
			3.0 V	-	0.2	0.4	V
			4.5 V	-	0.2	0.4	V
		I _O = 8 mA	2.3 V	-	0.6	1.0	V
			3.0 V	-	0.4	0.8	V
			4.5 V	-	0.3	0.6	V
		I _O = 16 mA	3.0 V	-	1.0	1.4	V
			4.5 V	-	1.1	1.5	V
		I _O = 24 mA	4.5 V	-	1.1	1.5	V
V _{OH}	HIGH-level output voltage	I _O = -100 μA	1.65 to 5.5 V	V _{CC} - 0.1	V _{CC} - 0.02	-	V
		I _O = -1 mA	1.65 to 5.5 V	V _{CC} - 0.15	V _{CC} - 0.08	-	V
		I _O = -4 mA	2.3 V	1.8	2.0	-	V
			3.0 V	2.6	2.8	-	V
			4.5 V	4.2	4.4	-	V
		I _O = -8 mA	2.3 V	1.4	1.7	-	V
			3.0 V	2.2	2.5	-	V
			4.5 V	3.9	4.1	-	V
		I _O = -16 mA	3.0 V	1.5	2.0	-	V
			4.5 V	3.3	3.8	-	V
		I _O = -24 mA	4.5 V	3.0	3.5	-	V
		I _{CC}	Supply current (quiescent)	V _I = GND, \overline{EN} = "0" I _O = 0 mA	5.5 V	-	100
I _I	Input current	V _I = V _{CC} or GND	1.65 to 5.5 V	-	-	±1	μA
I _{OPD}	Output leakage current	V _I = V _{CC} or GND \overline{EN} = "1"	1.65 to 5.5 V	-	-	±5	μA
I _{OFF}	Powerdown leakage current ⁽¹⁾	V _I = V _{CC} or GND	OFF ⁽²⁾	-	-	5	μA

(1) into any input or output port

(2) V_{CC} is disconnected or at GND potential

5.4 DYNAMIC CHARACTERISTICS

All parameters are specified across the entire operating temperature range unless otherwise specified.

Table 7: AC Electrical Characteristics

SYMBOL	PARAMETER	CONDITIONS	V _{CC}	MIN	TYP	MAX	UNITS
$t_{pd}^{(1)}$	Propagation Delay (Input A to Output B or Input B to Output A)	$C_L = 50 \text{ pF}$	4.5 to 5.5 V	-	7.6	11	ns
			3.0 to 3.6 V	-	9	13	ns
			2.3 to 2.7 V	-	11	15	ns
			1.65 to 1.95 V	-	17	25	ns
$t_{en}^{(2)}$	Output Enable Time (Input $\overline{\text{EN}}$ to Output A or B)	$C_L = 50 \text{ pF}$	4.5 to 5.5 V	-	15	25	ns
			3.0 to 3.6 V	-	22	35	ns
			2.3 to 2.7 V	-	29	41	ns
			1.65 to 1.95 V	-	43	53	ns
$t_{dis}^{(3)}$	Output Disable Time (Input $\overline{\text{EN}}$ to Output A or B)	$C_L = 50 \text{ pF}$	4.5 to 5.5 V	-	16	25	ns
			3.0 to 3.6 V	-	22	35	ns
			2.3 to 2.7 V	-	28	40	ns
			1.65 to 1.95 V	-	42	51	ns
t_{sk}	Channel-to-channel skew	$C_L = 50 \text{ pF}$	1.65 to 5.5 V	-	-	1	ns
C_{IN}	Input Capacitance ⁽⁴⁾	$V_I = V_{CC} \text{ or GND}$	1.65 to 5.5 V	-	2	4	pF
C_{PD}	Power dissipation capacitance ⁽⁴⁾	$I_O = 0 \text{ mA}, f = 1 \text{ MHz}$	5.5 V	-	40	-	pF

- (1) equivalent to t_{PLH} , t_{PHL}
- (2) equivalent to t_{PZL} , t_{PHL}
- (3) equivalent to t_{PLZ} , t_{PHZ}
- (4) guaranteed by design

5.5 RADIATION RESILIENCE

For detailed radiation testing reports, please contact Apogee Semiconductor at sales@apogeeseemi.com.

Table 8: Radiation Resilience Characteristics

PARAMETER	CONDITIONS	VALUE	UNITS
Total Ionizing Dose (TID)	Please contact Apogee Semiconductor for test report.	30	krad (Si)
SEE LET Threshold	Please contact Apogee Semiconductor for test report.	<80	MeV-cm ² /mg

5.6 CHARACTERISTICS MEASUREMENT INFORMATION

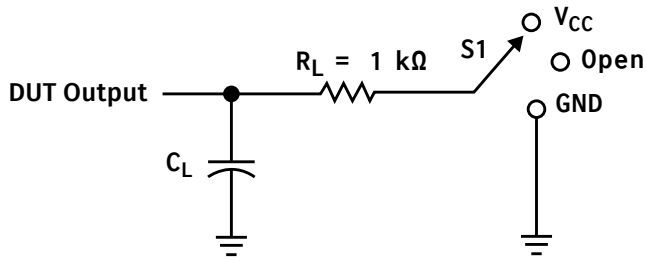

TEST	S1
t_{pd}	Open
t_{PLZ}, t_{PZL}	V_{CC}
t_{PHZ}, t_{PZH}	GND

Figure 3: Load circuit for 3-state outputs

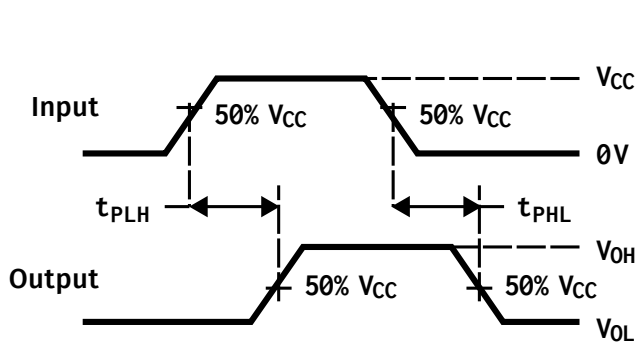

Figure 4: Propagation delay measurement

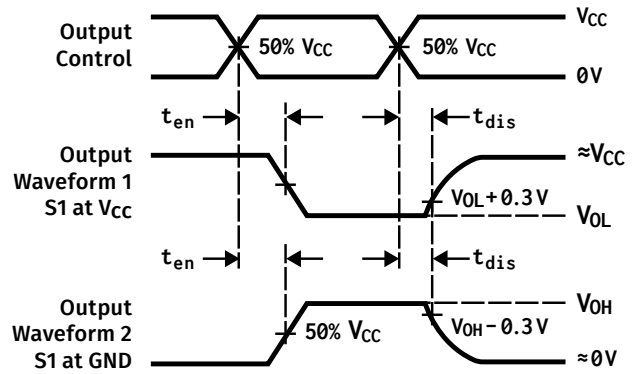

Figure 5: Enable and disable times, for low- and high-level enables

6 DETAILED DESCRIPTION

The AP54RHC506 is a 5-bit bus transceiver with 3-state outputs intended to perform the Boolean function **BUFF** ($Y = A$) in positive logic. Designed to operate from a wide supply voltage of 1.65 to 5.5 V, it has fully redundant input and output stages providing for superior resiliency to single event effects.

The output and input stages are constructed with transient activated clamps (Figure 6, 7) that prevent inadvertent biasing of the V_{CC} power rail through parasitic diodes inherent to conventional input, output, and ESD circuits. The IC also incorporates an internal power-on reset (POR) circuit that prevents the output from driving erroneous results during power-on, and guarantees correct operation at power supply voltages as low as 1.65 V. While the supply is ramping, the POR holds the output buffer in tri-state, a feature that prevents unwanted DC current during cold sparing on input and output pins.

The AP54RHC family's I/O protection circuitry allows for cold sparing configurations as it avoids a leakage current penalty on inputs and outputs while in a power-down state. This can result in considerable power savings in systems where multiple-path redundancy is employed. The ESD clamp circuits for this logic family are designed to support Class 2 ESD levels of 4 kV HBM and 500 V CDM.

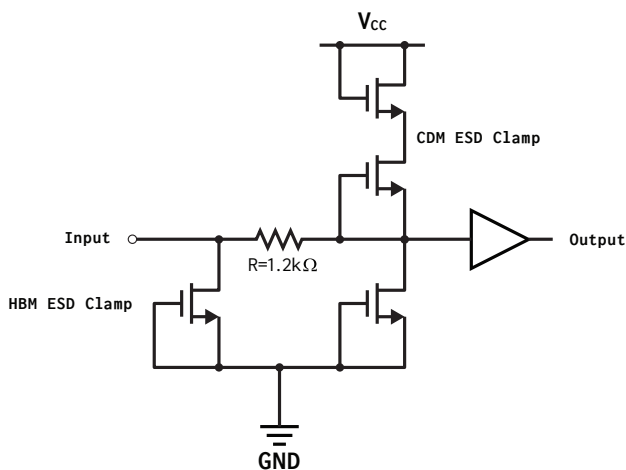

Figure 6: Details of input pin structure

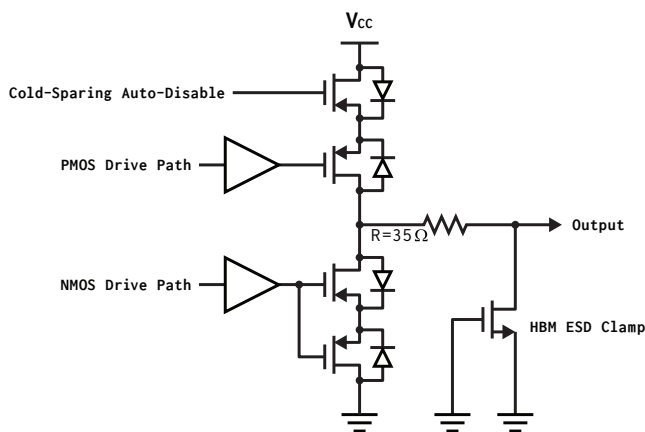

Figure 7: Details of output pin structure

7 APPLICATIONS INFORMATION

7.1 USE IN COLD-SPARING CONFIGURATION

As the AP54RHC family is radiation-hardened by design and includes internal TMR, it can be utilized in high-reliability applications without additional supporting circuitry or devices. Nonetheless, some application requirements call for fully-redundant designs, where an “A” and a “B” device are required, often on separate power rails.

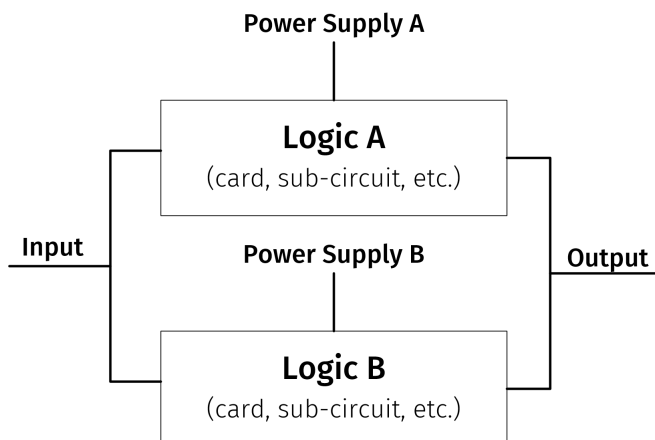

Figure 8: Two-path cold-sparing configuration.

With the cold-sparing capability of the AP54RHC family, fully redundant “A” and “B” functions may be placed in parallel (as seen in Figure 8) running off redundant power supplies. The inputs and outputs on each one of these functions are assumed to be based on the AP54RHC family, allowing for direct parallel connection without unwanted leakage current paths during cold sparing. In the event of a failure in power supply A or within function A, the system can simply shut power supply A off and switch on power supply B, without requiring additional input or output switching or configuration changes.

7.2 POWER SUPPLY RECOMMENDATIONS

This device can operate at any voltage within the range specified in [Table 4 Recommended Operating Conditions](#).

At a minimum, a 16 VDC (or higher), X7R-rated 0.1 μ F ceramic decoupling capacitor should be placed near (within 1 cm) the V_{CC} pin of the device.

7.3 APPLICATION TIPS

Unused **inputs** must **not** be left floating. They may be connected to either a low (GND) or high (V_{CC}) bias to provide a known state at the input of the device. Resistors may be used to tie off unused inputs. In the event of a design change, such resistors can be removed, thereby allowing use of the inputs without having to cut traces on the PCB.

An unused **output** may be left floating. It is suggested that it be routed to a test point or similar accessible structure in case the gate needs to be utilized as part of a design revision.

8 PACKAGING INFORMATION

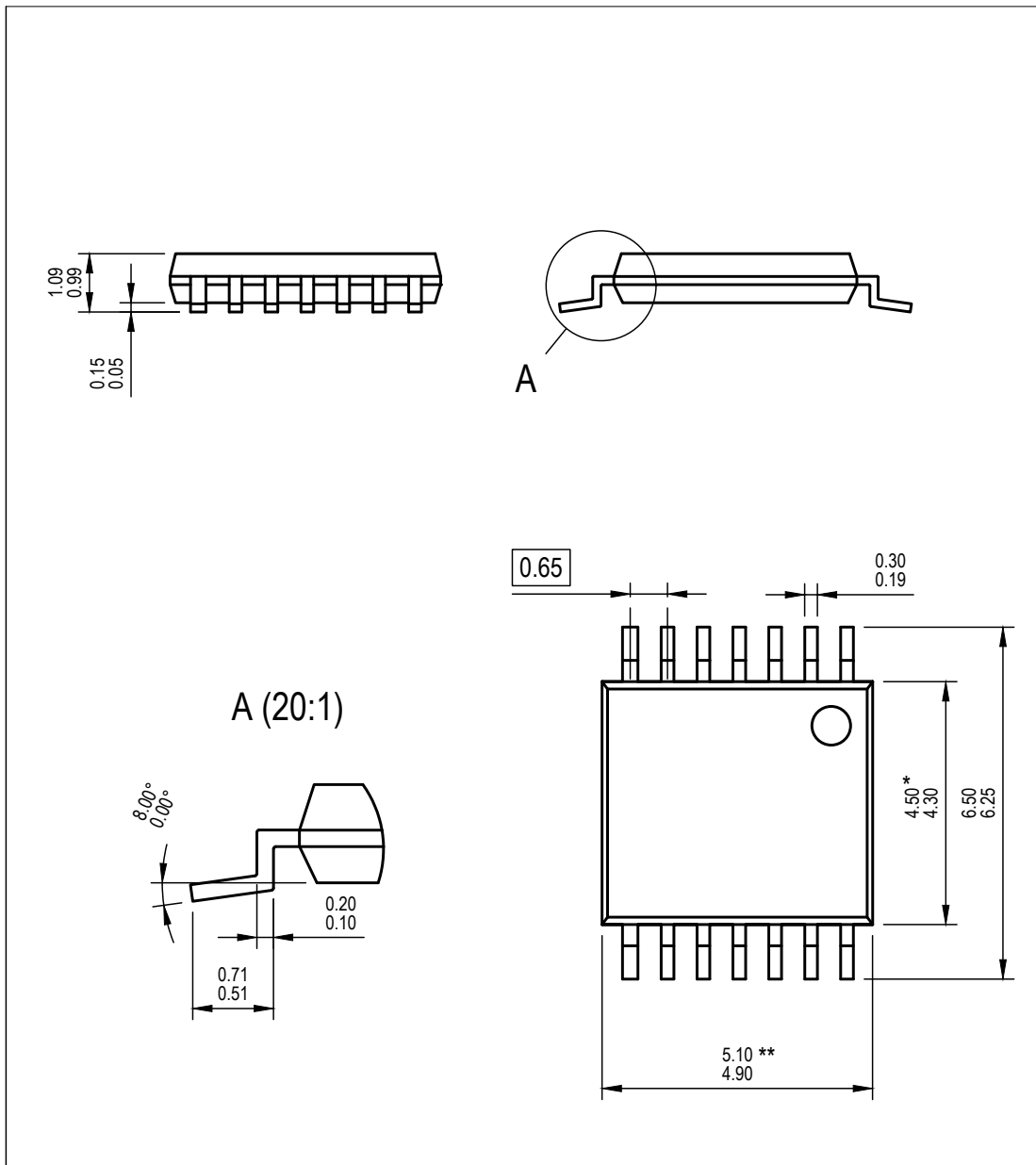

Notes:

1. All linear dimensions are in millimeters. Dimensioning and tolerancing are as per ISO/TS 128-71:2010
2. The part is compliant with JEDEC MO-153 specifications.

* Body width does **not** include interlead flash. Interlead flash shall not exceed 0.25 mm each side.

** Body length does **not** include mold flash, protrusion, or gate burrs. Mold flash, protrusions, and gate burrs shall not exceed 0.15 mm on each side.

Figure 9: Package Mechanical Detail

9 ORDERING INFORMATION

Example part numbers for the AP54RHC506 are listed in Table 9. The full list of options for this part can be found in Figure 10. Please contact Apogee Semiconductor sales at sales@apogeesemi.com for further information on sampling, lead time and purchasing on specific part numbers.

Table 9: AP54RHC506 Ordering Information

DEVICE	DESCRIPTION	PACKAGE
AP54RHC506ELT-W	Radiation Hardened 5-channel Bus Transceiver (for evaluation only)	Plastic TSSOP-14
AP54RHC506ALT-R	Radiation Hardened 5-channel Bus Transceiver (30 krad (Si))	Plastic TSSOP-14

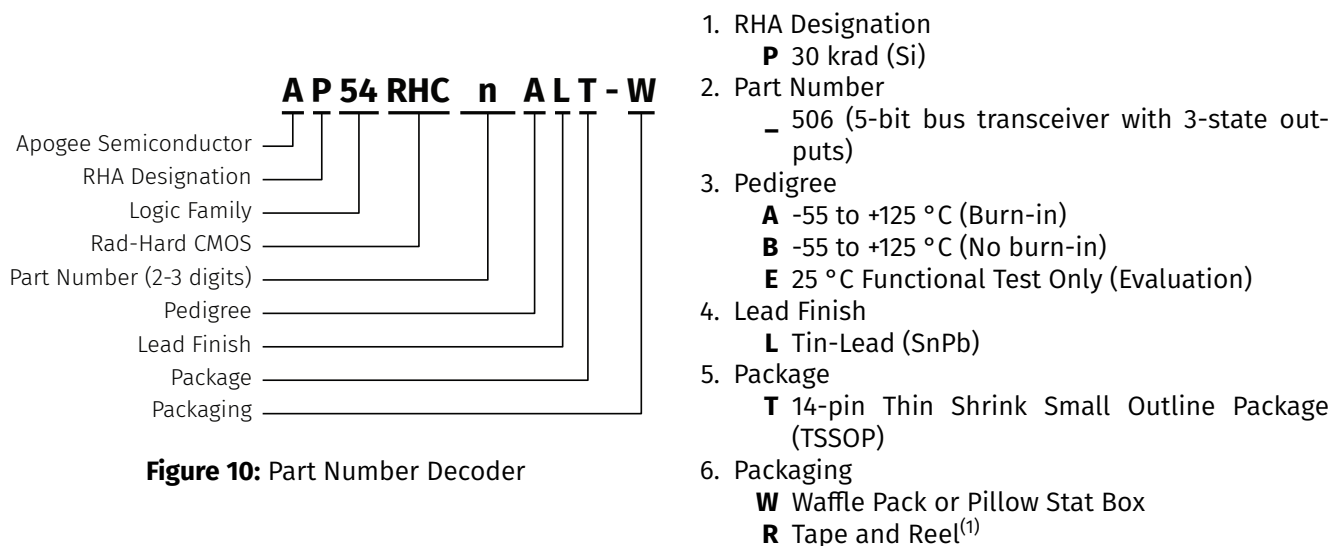

Figure 10: Part Number Decoder

⁽¹⁾ [Contact us](#) for custom reel quantities. Orders less than full reel quantities may be shipped as cut tape.

10 REVISION HISTORY

REVISION	DESCRIPTION	DATE
A04	Updated ordering information.	2021-07-30
A03	Update and clean-up of static and dynamic characteristics.	2021-06-23
A02	Update Static and Dynamic characteristics.	2020-08-07
A01	Initial public release.	2020-02-29
A00	Initial internal release.	2019-07-05

For the latest version of this document, please visit <https://www.apogeesemi.com>.

11 LEGAL

All product, product specifications and data are subject to change without notice.

Apogee Semiconductor provides technical data (such as datasheets), design resources (including reference designs), reliability data (including performance in radiation environments), application or other design advice, safety information, and other resources **“as is”** and with all faults, and disclaims all warranties, express and implied, including without limitation any implied warranties of merchantability, fitness for a particular purpose or non-infringement of third party intellectual property rights. These resources are intended for skilled engineers with understanding of high reliability and high radiation environments and its complexities.

Apogee Semiconductor is not responsible for: (1) selecting the suitable products for a given application, (2) designing, verifying, validating and testing it, or (3) ensuring that it meets any performance, safety, security, or other requirements. These resources are subject to change without advance notice. The use of these resources is restricted to the development of an application that uses the Apogee Semiconductor products described in them. Other reproduction and display of these resources is prohibited. No license is granted to any other Apogee Semiconductor intellectual property right or to any third-party intellectual property right.

Apogee Semiconductor disclaims responsibility and reserves the right to demand indemnification for any claims, damages, costs, losses, and liabilities arising out of wrongful use of these resources. The products are provided subject to Apogee Semiconductor's [Terms of Sale](https://www.apogeesemi.com/terms) (<https://www.apogeesemi.com/terms>) or other applicable terms provided in conjunction with applicable products. The provision of these resources does not expand or otherwise alter applicable warranties or warranty disclaimers for Apogee Semiconductor products.

Purchasers of these products acknowledge that they may be subject to and agree to abide by the United States laws and regulations controlling the export of technical data, computer software, electronic hardware and other commodities. The transfer of such items may require a license from the cognizant agency of the U.S. Government.